

### Ideal for pilot plants and small-scale production

The Admix Pilot Scale in-tank high shear mixer is an excellent solution for product development, formula optimization, trial mixtures, and small production runs. Admix Pilot Scale Mixers come with a mobile lift stand and an optional variable frequency drive (VFD) to allow for the precise control of rotational speed, tank turnover rate, pumping rate, mixing intensity, rotor tip speed and shear rate.

The Pilot Scale Mixer is available in two versions: the RS-02 with our Rotosolver high shear impeller or the XP-02 with our Rotostat high shear impeller.

**NEW  
LIFT  
STAND  
DESIGN!**



### The RS-02 Pilot Scale Mixer:

The RS-02 comes with our flagship, patented Rotosolver® high shear mixing head. The Rotosolver is the most effective high shear impeller on the market for wetting out and dispersing powders. Its patented design is engineered to provide the optimal balance between shear and flow so that your product is completely homogenous, emulsified, and agglomerate-free in under 10 minutes. Powders, even when dumped in all at once, are immediately drawn down into the mixing head and up from the bottom, passing through multiple shear surfaces before centrifugal pressure forces material to the periphery. This combination of high shear, converging forces and continual flow means there are no dead zones in the tank and mixing is completed faster. Because of the highly efficient flow pattern created by a unique head design, minimal horsepower energy is needed to run the mixer and very little heat is generated so the temperature of your mixture remains steady. In addition, because no unmixed product is left behind, product loss concerns are a non-issue. With the Rotosolver, your ingredients will be perfectly mixed with functional ingredients intact and emulsions stable.

**ROTOSOLVER®**  
head for RS-02

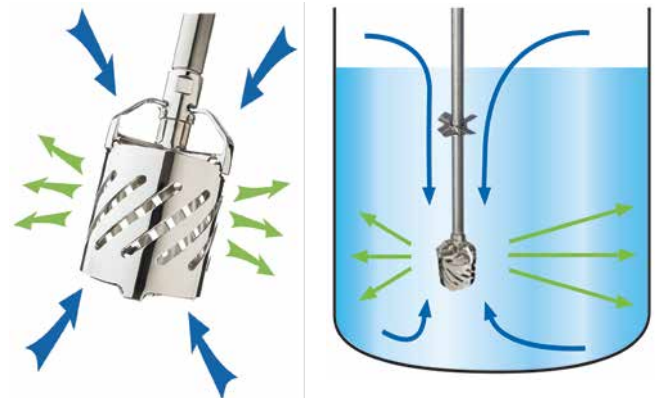

### The XP-02 Pilot Scale Mixer:

When reducing the particle size of certain materials such as fruit chunks, candy pieces, or nuts for example, the XP-02 is a suitable option. The XP-02 comes with our patented Rotostat® rotor-stator impeller and optional lower propeller.

**ROTOSTAT®**  
head for XP-02



## Featured benefits of Admix Pilot Scale Mixers:

- Large, easy-to-turn hand crank for adjusting mixer height
- Sturdy and mobile lift stand
- Wide base for added stability
- Fits through standard doorways
- Simple installation – use immediately!
- Optimal shear and flow patterns
- Low power consumption
- Scale-up is guaranteed!\*
- Suitable for every industry

\*We are so confident that our mixers will perform as expected, that we provide a Process Guarantee. This is the Admix guarantee that when scaling up to larger batches, we will build you a production size Rotosolver or Rotostat high shear mixer for your application and tank size that will provide the same mixing performance as your pilot scale unit. This gives you peace of mind that transitioning to higher production levels will be seamless and results will be repeatable, predictable, consistent and stable every time!



**QUICK SHIP** ▶▶▶

*Ships in 2 days!*

### Quick Ship configuration includes:

- Pilot scale mixer with 1.5hp SS motor, SS bearing frame, SS shaft
- 60 mm Rotosolver® high shear mixing head with 3 in. / 76 mm upper propeller
- Motor inverter (VFD) mounted to lift stand
- 10-gal. / 37-liter Nalgene® tank
- Safety cover guard
- Mobile lift stand

	RS-02 (with Rotosolver head)	XP-02 (with Rotostat head)
<b>Batch Capacity</b>	5 – 20 gallons / 19 – 76 liters	5 – 20 gallons / 19 – 76 liters
<b>Scalable</b>	✓	✓
<b>Shear Head Diameter</b>	2.36 in. / 60 mm	2.48 in. / 63 mm
<b>Second Impeller</b>	3 in. / 76 mm upper propeller optional	3 in. / 76 mm lower propeller optional
<b>Seal Type</b>	Low pressure lip seal	Low pressure lip seal
<b>Tank / Bucket</b>	Nalgene available (10 gal./37-liter bucket)	Nalgene available (10 gal./37-liter bucket)
<b>Tank Safety Cover</b>	✓	✓
<b>Lift Stand on Casters</b>	✓	✓
<b>Motor Size</b>	1.5 HP / 1.1 kw	1.5 HP / 1.1 kw
<b>Output Speed (RPM)</b>	3450	3450
<b>Motor Type Options</b>	Stainless Steel (included) High efficiency TEFC or TEXP, White Washdown Duty	Stainless Steel (included) High efficiency TEFC or TEXP, White Washdown Duty
<b>VFD Motor Controller</b>	Optional, recommended	Optional, recommended
<b>Input Voltage</b>	1/60/115-230 or 3/60/230-460	1/60/115-230 or 3/60/230-460
<b>Full Load Amps</b>	230v: 3.7 amps / 460v: 1.8 amps	230v: 3.7 amps / 460v: 1.8 amps

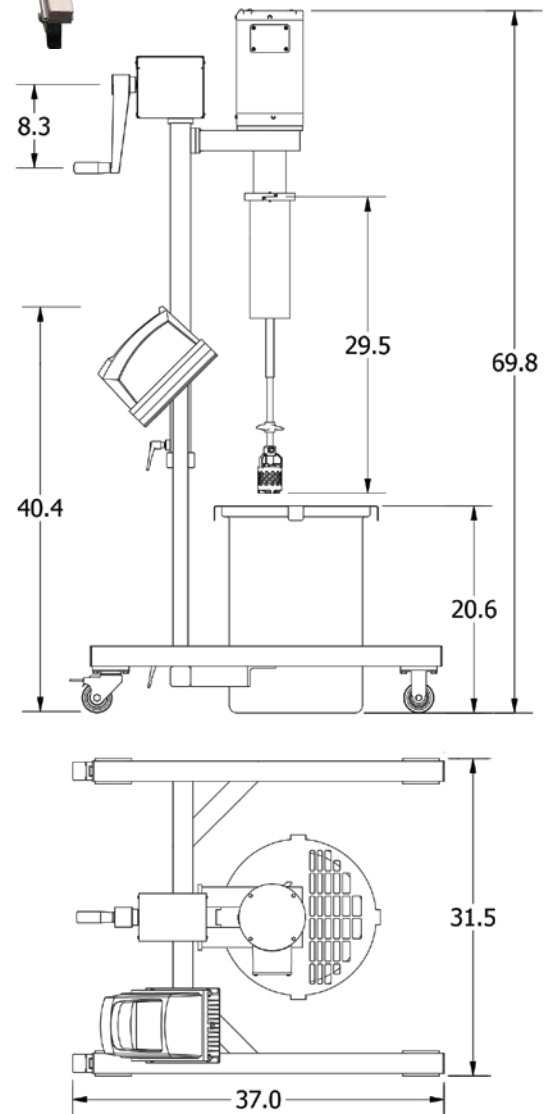

Advanced Mixing Technologies

R-Cap Process Equipment is an authorized sales representative of Admix, Inc.

**R-Cap Process Equipment, Inc.**

Website: [www.r-cap.com](http://www.r-cap.com)

Email: [rcap@r-cap.com](mailto:rcap@r-cap.com)

Main Office: 847.382.3003

Michigan Office: 248.977.5225

